

Metrological characterization of a textile temperature sensor

Lorenzo Quartini, Andrea Zanobini

Department of Information Engineering, Via Santa Marta, 3 Florence, Italy

University of Florence, Italy. Email: andrea.zanobini@unifi.it

Abstract — This paper presents the study of a new generation textile temperature sensor, in two different heated ovens. The first chamber was used to evaluate temperature and the last one for the evaluation of both temperature and humidity. An acquisition system of LabVIEW and another one of Agilent were developed, involving even thermocouples and Pt100. The results show many metrological characteristics proving that the sensor is an RTD type.

Index terms—Metrological, RTD, temperature sensor, textile industry.

I. INTRODUCTION

Temperature and relative humidity are essential elements in museums and in collections care. Get the conditions wrong and you could find items ruined. Mould, pests, deterioration and warping are just a few of the problems that can happen if these elements are not stable and controlled.

A. Humidity

In case of humidity all the organic materials degrade. Plants and animals contain a high proportion of water, so it's unsurprising that their products also retain moisture. When materials absorb and retain moisture, they are described as hygroscopic. Such materials can and will absorb or give off moisture until they reach a state of equilibrium with the air that surrounds them. These materials include: Wood, paper, cotton, linen, wool, silk, parchment, leather, fur, feathers, ivory, bone, horn. When the surrounding air is very dry, organic materials will give off some of their moisture. They become brittle and may shrink, warp, split or crack. When the surrounding air is damp, the materials will absorb some of the moisture from the air. They may swell, cockle, warp, change shape or lose strength. Dampness can also cause mould and fungal growth on organic materials. Also inorganic materials such as glass, ceramics, metals and minerals are also affected by high or low humidity. Materials that have a natural salt content may suffer from efflorescence when the air is dry. The salts in deteriorated

glass, porous ceramics and some geological material are carried to the surface by moisture (which may have entered the pores during a period of higher humidity). The moisture evaporates and the salts crystallise on the surface. Other effects on inorganic material include: corrosion in metals, faded dyes and pigments, pyrite decay in geological materials. If the humidity of the air changes frequently, hygroscopic materials will swell and shrink repeatedly. This causes internal stress and damage. This is particularly a problem in composite objects where the different materials have different rates of shrinkage. The expansion of one material may force changes in the dimensions of another, causing considerable tension and eventually damage. Look out for such damage in items such as skins on drums and paintings on wooden panels. Moisture can also start or speed up the damaging effect of air pollutants and other harmful substances on many museum item.

B. Temperature

Objects themselves are rarely directly affected by temperature. Fluctuating heat, however, can damage or compromise items in indirect ways. Uncontrolled temperatures can cause changes in humidity, damaging sensitive objects through RH fluctuations. This is the main reason for controlling temperature. Other reasons include: speed up chemical processes and biological activity, make certain materials expand and contract. This is particularly damaging for composite materials where parts expand at different rates. Also high or low temperatures can affect the comfort of people working with or visiting collection items.

Moreover temperature and humidity affect each other. The humidity of the air depends on the temperature. Where one cubic metre of air holds 10g of water at 10°C, the same volume can hold over 30g when the air is heated up to 30°C. Measuring the amount of moisture in grammes, or absolute humidity, doesn't mean much when monitoring a museum's environment. 10g of water feels damp at 10°C but will seem dry at 30°C.

Instead, the environment in museums is measured in relative humidity (RH). This is expressed as a percentage of the maximum amount of water the air can hold at that temperature. For example:

- At 10°C, 10g water is the maximum amount the air can hold, so the RH is 100%.
- At 30°C, 10g is about one-third of the maximum amount, therefore the RH is approximately 33%.

When the temperature changes, for instance after the sun has set, so too does the RH. This principle is one of the most important factors in environmental control in a museum.

C. Environmental recommendations

The recommended temperature for museum items is 16 to 20°C. Moderately fluctuating temperatures between 10 and 20°C are unlikely to adversely affect museum items. Rooms below 16°C become too uncomfortable for visitors, while anything below 10°C can cause condensation and affect RH. Temperatures above 20°C will be too hot for guests and can accelerate degradation in museum objects. Museum stores can be cooler than 16°C as they are not frequented by visitors. Bear in mind that items will need to acclimatise gradually between storage and display. Relative humidity should not drop below 40% or rise above 70%. Relative humidity below 40% can cause sensitive items to become dry and brittle. The maximum level is determined by the point that fungal growth begins, which is at an RH of at least 70%. Reducing the fluctuation of RH is also important. These are broad recommendations. Some items and materials require more specifically controlled levels of relative humidity. In a naturally ventilated building in sound condition, indoor conditions will respond to outdoor conditions. There are, however, mitigating factors that can affect the temperature and humidity inside a building, room or display case.

D. Continuous monitoring with sensors

As so many factors can affect the temperature and humidity in a museum, the environment must be regularly monitored to keep track of fluctuations. After 12 months of monitoring you will have developed a good idea of changing environmental conditions in your museum. Use the information gained from monitoring to work out where and how to display sensitive items from your collections, investing in control equipment if necessary. When continually monitoring your museum, pay particular attention to regular, frequent fluctuations, which can cause significant damage to museum items. The changes take place slowly enough for the objects to adjust to them, but fast enough to cause frequent movement, stress and fatigue in the material. Occasional very rapid fluctuations, within one or two hours, will have a less damaging effect on items. Very gradual fluctuations will give the items enough time to acclimatise slowly.

Some types of items are more affected by fluctuations than others. When transporting items to an area with different environmental conditions, keep items well packed and wrapped in acid-free tissue and a box or blanket. This will ensure that acclimatisation to the new conditions can take place gradually. Maintaining stable humidity and temperature in your museum can use up a lot of energy. This costs a lot of money and can also increase building's negative environmental impact. Although maintaining stability is essential to the care of museums, some factors can be put in place to increase energy efficiency. Take a slightly more flexible approach to environmental control and look for ways to reduce artificial means of altering temperature and humidity. This may mean allowing a greater range of desired RH and temperature but can reduce carbon footprint.

II. TEXTILE SENSORS

Textile sensors are the future, they are fabrics that feature electronics and interconnections woven into them [1] [2], presenting physical flexibility and typical size that cannot be achieved with other existing electronic manufacturing. Conductive fibres are the key element to build the sensor [3]. Sensor is a RTD [4] according to the builder. Purpose of this study is to prove it by showing the linearity of textile sensor [5] and searching for a mathematical function similar to theoretical model $\rho(T) = \rho_0 \cdot [1 + \alpha(T - T_0)]$. By using $R = \rho \cdot L/S$ it is possible to use resistive model $R(T) = R_0 \cdot [1 + \alpha(T - T_0)]$. Firstly, the study examined the behaviour of temperature in an internal science oven situated in a reliability laboratory at Analytical Cetace in Scandicci (Firenze, Italy). Successively the behaviour of temperature and humidity was analyzed in the second oven chamber. This document proposes to characterize the textile [6] temperature sensor given by Plug & Wear Srl (Firenze, Italy). The temperature experiment [7] is divided in four stages: first step is to avoid all contact resistances and put the sensor on an insulating material, second step was aimed at implementing a measurement system by developing a specific software through LabVIEW, third step consisted of data acquisition and finally the study of result was carried out. Temperature acquisition was performed with an Agilent software. The humidity experiment required the same stages. During both experiments to measure temperature, thermocouples and one Pt100 [8] [9] were supported by the sensor but data elaboration was performed by considering Pt100 because of his high accuracy. Collected data have produced: linearity, hysteresis, sensibility, output range and input range.

III. METHODOLOGY

A. Resistance settings

Resistance has been measured by using 4 wire method and a digital multimeter HP-34401A [10]. Resistance

acquisition has been performed using an application of LabVIEW [11], as shown in figure 1. To connect the multimeter and PC a GPB-USB-NHI of National Instruments has been used.

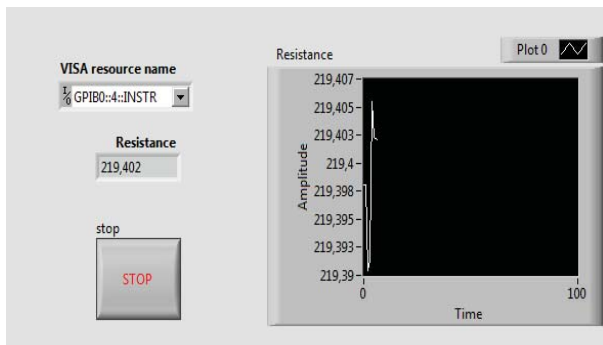
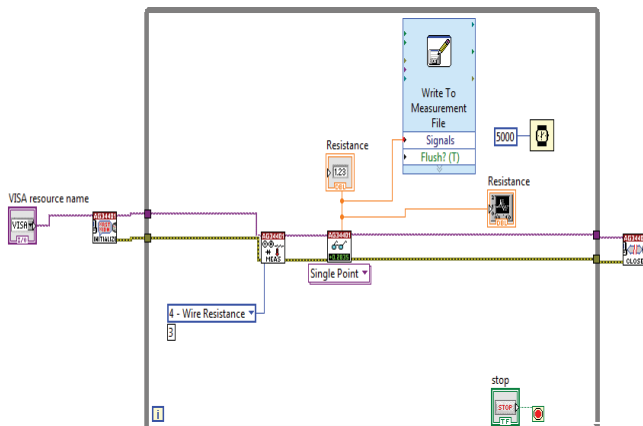

Fig.1. Code created in LabVIEW with 34401A drivers and front panel.

B. Temperature settings

Temperature has been measured with a data acquisition of Agilent 34970A [12] [13] using a Pt100, as shown in figure 2. Temperature acquisition has been performed using a software Agilent Benchlink Data logger. To interface PC and data acquisition an USB/GPIB of Agilent has been employed.

C. First experiment analysis method

Data have been collected every 5 seconds throughout the period of prove, both for temperature and for resistance. Results have been reworked using Excel. In figure 3 experiment setting is shown. All the measurements have been done after a warm up period of each instruments of about 30 minutes. Temperature has been changed quickly [14] from -10°C to 103°C, using WEISS SB11500 chamber.

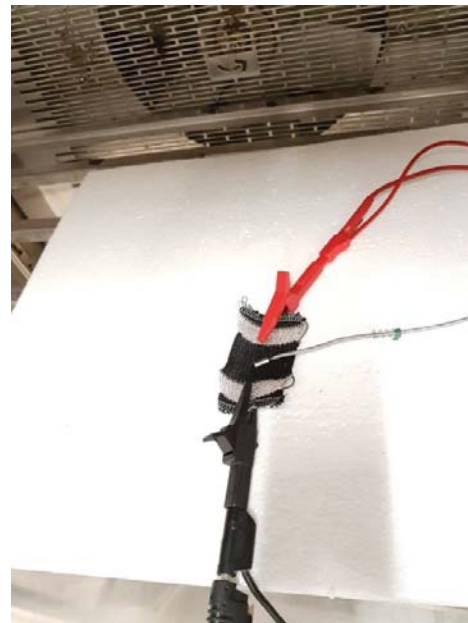

Fig.2. Temperature sensor and Pt100.

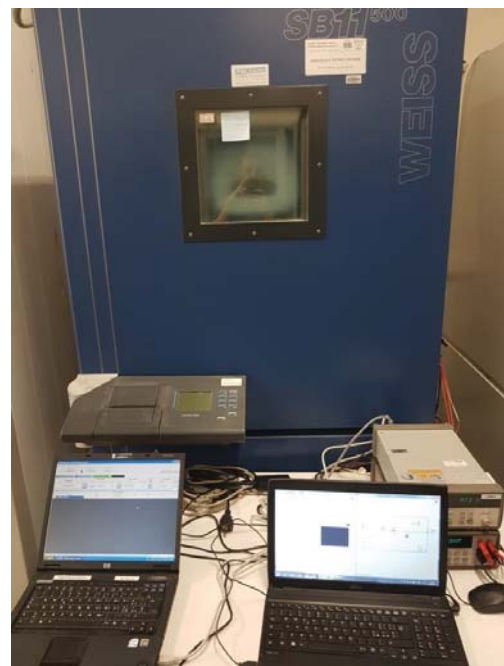

Fig.3. First experiment setting.

D. Second experiment analysis method

Temperature has been changed by step of 5 degrees centigrade from -10°C to 80°C using challenge 1200 ACS chamber, as shown in figure 4. Data have been collected cyclically every 5 seconds, when temperature was exactly at the set point for a period of 15 minutes. Results have been reworked using Excel. Pt100 has been positioned to 5 millimetres from the sensor, as observable in figure 5. All the measurements have been done after a warm up period of each instruments about 30 minutes.



Fig.4. Challenge 1200 ACS oven chamber.



Fig.5. Pt 100 at 5mm from sensor

E. Third experiment analysis method

Humidity [15] has been analysed by setting temperature at 30°C and varying it from 30% to 90%, by dividing the range in 4 steps. At the set point, data has been collected every 5 seconds for a period of 30 minutes with the same tools and automated acquisition system used in previous experiments. Humidity has been studied in challenge 1200 ACS oven chamber. Results have been reworked using Excel.

IV. DATA ANALYSIS

A. First experiment data

The aim of this study is to know how sensor respond to a rapid variation of temperature. As seen in figure 6, resistance variation seems linear but resistance values

are not correct because of a quick temperature overview. Data have never stabilized.

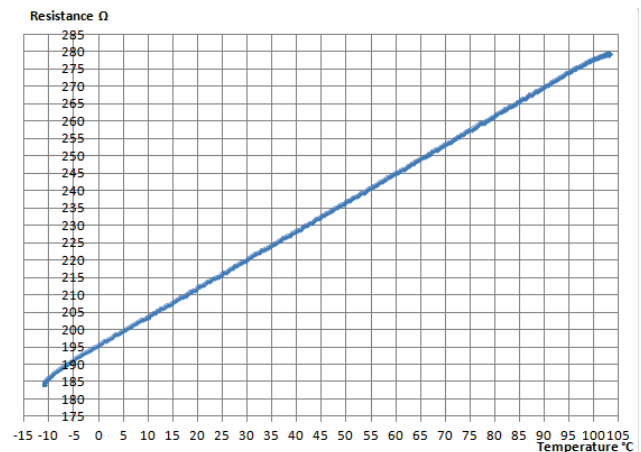

Fig.6. Preliminary graph of resistance as temperature function, in blue all sampled points.

B. Second experiment data

This study has been done to obtain a function and more accurate data than previous one, by sampling in a more dense way. Due to sensor linearity has been chosen to sample in 19 step every 5 degrees centigrade. Results is shown in figure 7. Data were analyzed with statistical method of linear regression an additional Excel tool.

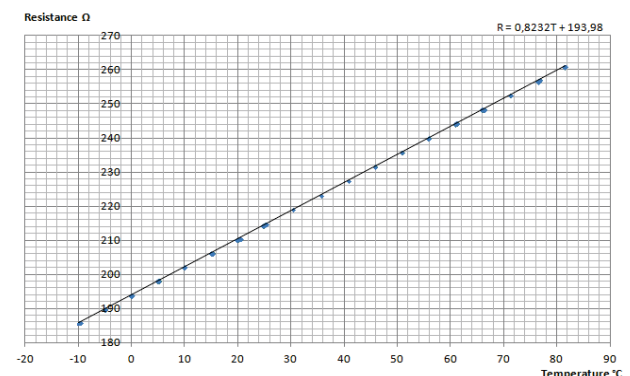

Fig.7. Final graph of resistance as temperature function, in blue all sampled points, in black linear regression line.

$R=0,8232T + 193,98$ characterize the sensor. Sensor

sensitivity [16] is defined as $S = \frac{dy}{dx}$ so is equal to $0,8232[\Omega/°C]$. Because of this result it was decided to calculate the uncertainty of measurement to understand how it could affect resistance values. Type A uncertainty [17] is evaluated by statistical method due to result of repeated measurements of resistance at the same temperature and is equal to $u_A = \frac{s}{\sqrt{n}}$ with s =standard deviation and n =samples acquired. Type B uncertainty is evaluated by using information obtained

from the manufacturer's manual and is equal to $u_B = \frac{\alpha}{\sqrt{3}}$ with α = accuracy of the instrument. Total uncertainty: $u_T = \sqrt{u_A^2 + u_B^2}$. All the results are shown in table I and in figure 8.

TABLE I
 RESULTS OF RESISTANCE MEASUREMENT

T [°C]	R [Ω]	u [Ω]	T [°C]	R [Ω]	u [Ω]
-10	185,88	±0,02	35,7	223,24	±0,02
-5	189,74	±0,02	40,7	227,46	±0,02
0	193,88	±0,02	45,7	231,67	±0,02
5	198,06	±0,02	50,8	235,84	±0,02
10	202,14	±0,02	55,8	240,01	±0,02
15,3	206,24	±0,02	60,9	244,23	±0,02
20,3	210,32	±0,02	66	248,38	±0,02
25,3	214,84	±0,02	71,2	252,60	±0,02
30,3	219,06	±0,02	76,5	256,91	±0,02
81,5	260,96	±0,02			

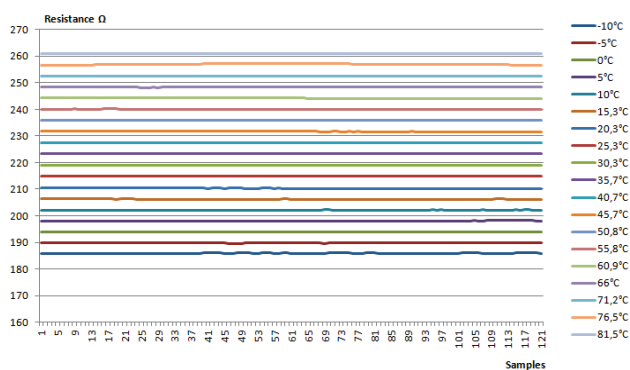

Fig.8. Chart with all the resistance samples at same temperature

C. Third experiment data

The objective of this investigation is to evaluate humidity [18] impact on resistance value. As for prior measurement, uncertainty was calculated as shown in table II. Figure 9 shows the results.

TABLE II
 RESISTANCE MEASUREMENT WITH HUMIDITY EFFECTS

Resistance [Ω]	Humidity %	Uncertainty[Ω]
219,37	30	±0,02
219,36	50	±0,02
219,36	70	±0,02
219,50	90	±0,02

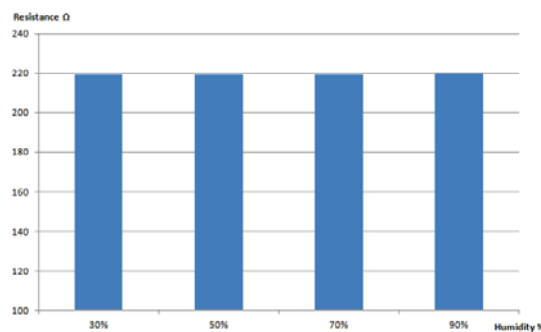

Fig.9. Histogram representing a non-significant variation of resistance depending on humidity.

V. CONCLUSION

The experiments produced the following metrological characteristics: linearity, sensitivity equal to 0,8232 [Ω/°C], measurement range from -10°C to 81,5°C, operating range from (185,88 ±0,02)Ω to (260,96 ±0,02)Ω, non-significant hysteresis. No significant variation of resistance values was obtained by introducing humidity factor. During first experiment, the feasibility of method used and repeatability have been demonstrated. During second and third experiment reproducibility of the method used has been showed. The aim of this investigation was also to create a function able to take resistance values and return them into temperature values, as shown in figure 10. The final function is $T=1,214R - 235,62$, an important result.

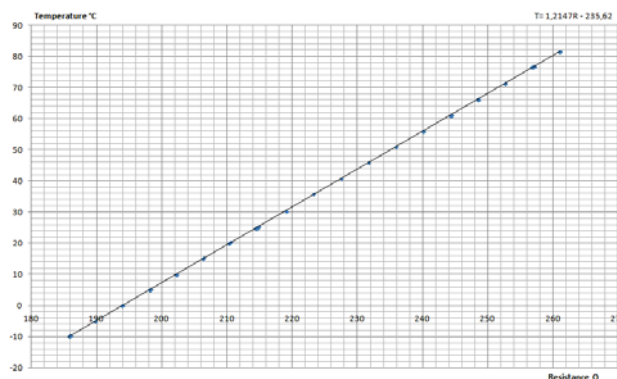

Fig.10. Final graph of temperature as resistance function, in blue all sampled points, in black linear regression line.

Criticism of hysteresis are the acquisition method. Data were acquired during WEISS SB11500 chamber cooling phase to reach -10°C. However, it has not done a dense sampling in certain steps. Resistance values in descent are very similar to those that would be found using the function obtained during second experiment. In future, it can be suggested that additional hysteresis studies should be done. During the test in relative humidity at 90%, challenge 1200 ACS oven chamber had problems to maintain temperature at 30°C.

Therefore, being the sensor very sensitive to even small changes in temperature, it has been deduced that the increase of approximately $0,13\Omega$ in resistance values is due to this factor. It would be interesting to increase measurement range and operating range, reaching the edge temperature of oven chambers. Also, all the function founded could be refined, further going to make a broad sampling degree by degree. Many studies have opened on this sensor about: pilling, aging, textile strain, salt fog, chemical swear and many others. For textile sensor, several future developments could be suggested to add to the one analysed in this paper: implementation in biomedical systems for the measurement of body temperature in infants, measuring temperature of a surface or a tube and to get into very tight spaces, where Thermal imaging cameras can't reach.

REFERENCES

- [1] M. Stoppa, A. Chiolerio, "Wearable Electronics and Smart Textiles: A Critical Review," *Sensors* 2014, vol. 14, no. 7, pp. 11957-11992, Jul 2014.
- [2] Rudiger Zeitler, "A New Optical Sensor for Measuring the Velocity of Webs by Correlation Techniques," *IEEE Transaction on Instrumentation and Measurement*, vol. 47, no. 1, pp. 289-292, Feb 1998.
- [3] L. Capineri, "Resistive sensors with smart textiles for wearable technology: from fabrication processes to integration with electronics," *Procedia Engineering*, vol. 87, pp. 724 – 727, 2014.
- [4] Chen, Anshi Zu, Jing Li, Bin, "Temperature compensation for hot-film crosswind sensors," *IEEE Transaction instruments and measurement Technology Conference*, Ottawa, Canada, May 1997.
- [5] Aiguo Song, Senior Member, IEEE, Yezhen Han, Haihua Hu, and Jianqing Li, "A Novel Texture Sensor for Fabric Texture Measurement and Classification," *IEEE Transaction on Instrumentation and Measurement*, vol. 63, no. 7, pp. 1739-1747, Jul 2014.
- [6] Pascale Godts, Daniel Dupont, and Didier Leclercq, "Direct measurement of the Latent Heat of Evaporation by Flowmetric Method," *IEEE Transaction on Instrumentation and Measurement*, vol. 54, no. 6, pp. 2364-2369, Dec 2005.
- [7] Vitor H. Carvalho, Paulo J. Cardoso, Michael S. Belsley, Rosa M. Vasconcelos, and Filomena O. Soares, "Yarn Hairiness Characterization Using Two Orthogonal Directions," *IEEE Transaction on Instrumentation and Measurement*, vol. 58, no. 3, pp. 594-601, Mar 2009.
- [8] Waldemar Nawrocki, "Measurement Systems and Sensors," Artech House, 2016.
- [9] M. Arai and K. Yamazawa, "High-temperature furnace controlled by a platinum resistance thermometer," in *SICE 2004 Annual Conference*, vol. 2, pp. 1172–1175, Aug 2004.
- [10] Agilent Technologies\HP, "HP 34401A Multimeter," Mar 2000.
- [11] Liang Wen, Jian X. Jin, Xiao Y. Chen, and Lin Jiang, "A Universal LabVIEW-Based HTS Device Measurement and Control Platform and Verified Through a SMES System," *IEEE Transaction on Applied Superconductivity*, vol. 24, no. 5, Oct 2014.
- [12] Agilent Technologies, "Agilent 34970A Data Acquisition/Switch Unit Family Product Overview 34970A 34972A," 2010.
- [13] Bortolino Saggini, Marco Tarabini, and Gerardo Lanfranchi, "A Device for the Skin-Contact Thermal Resistance Measurement," *IEEE Transaction on Instrumentation and Measurement*, vol. 61, no. 2, pp. 489-495, Feb 2012.
- [14] Dongwan Ha, Student Member, IEEE, Kyoungho Woo, Scott Meninger, Member, IEEE, Thucydidis Xanthopoulos, Member, IEEE, Ethan Crain, and Donhee Ham, Member, IEEE, "Time-Domain CMOS Temperature Sensors With Dual Delay-Locked Loops for Microprocessor Thermal Monitoring," *IEEE Transaction on Very Large Integration (VLSI) Systems*, vol. 20, no. 9, pp. 1590-1601, Sep 2012.
- [15] Muhammad Dawood Husain, Ozgur Atalay, Richard Kennon, "Effect of Strain and Humidity on the Performance of Temperature Sensing Fabric," *International Journal of Textile Science*, vol.2, no. 4, pp. 105-112, 2013.
- [16] Alejandro Martinez-Ríos, Gilberto Anzueto-Sanchez, Romeo Selvas-Aguilar, Arturo Alberto Castillo Guzman, Daniel Toral-Acosta, Valentin Guzman-Ramos, Victor M. Duran-Ramirez, J. Ascencion Guerrero-Viramontes, and Carlos A. Calles-Arriaga, "High Sensitivity Fiber Laser Temperature Sensor," *IEEE Sensor Journal*, vol. 15, no. 4, pp. 2399-2402, Apr 2015.
- [17] John R. Taylor, "An Introduction to Error Analysis: The Study of Uncertainties in Physical Measurements," University Science Books, 1997.
- [18] Reto Bhunjun, Rolf W. Vogt, "Sensor System for Contactless and Online Moisture Measurements," *IEEE Transaction on Instrumentation and Measurement*, vol. 50, no.11, pp. 3034-3040, Nov 2010.
- [19] <https://www.museumsgalleriesscotland.org.uk>