

Improvement of calibration capabilities with an *a posteriori* evaluation of the lightning impulse international comparison EURAMET.EM-S42

S.E. Caria^{1,2}, P.E. Roccatò³

¹ *Istituto Nazionale di Ricerca Metrologica (INRiM), Strada delle Cacce 91, 10135 Torino, Italy, s.caria@inrim.it*

² *Politecnico di Torino, Corso Duca degli Abruzzi 24, 10129 Torino, Italy, stefano.caria@polito.it*

³ *Istituto Nazionale di Ricerca Metrologica (INRiM), Strada delle Cacce 91, 10135 Torino, Italy, p.roccato@inrim.it*

Abstract – By the evaluation of the EURAMET.EM-S42 intercomparison results, the Laboratorio Alte Tensioni e Forti Correnti (LATFC) of Istituto Nazionale di Ricerca Metrologica (INRiM, Italy NMI) starts an analysis of the calibration capabilities with the developed measuring system for lightning impulse voltages.

This paper addresses the issue of the expanded uncertainty re-evaluation for the INRiM's CMCs up to 200 kV according to a new analysis of the comparison reference value (CRV), without affecting the results of the other participants in the comparison for all the involved lightning impulse parameters.

A validation of the new uncertainty values has been performed by means the calculation, for some test data waveforms extract for reference standard IEC 61083 - 2, of the convolution with the measured divider step response.

I. INTRODUCTION

The INRiM's Laboratorio Alte Tensioni e Forti Correnti (LATFC, High Voltage and High Power Laboratory) has the instrumentation to perform calibrations with lightning impulse (LI) waveforms up to 700 kV.

In 2016 started the Supplementary comparison EURAMET.EM-S42 [1, 2], for lightning impulse voltage measurement systems, in which thirteen institutes worldwide participate to the comparison. During the comparison were analyzed different LI waveforms: from 100 kV to 700 kV of peak value, name of test voltage value, with different polarities and different front time (short and long), from 0,84 μ s to 1,56 μ s, and with a time to half value of about 60 μ s.

The LATFC laboratory of the INRiM was one of the participants of the comparison, in the 2017 springtime, during European circulation of the Transfer reference measurement system (TRMS). The TRMS is based on a

commercial divider combined with its acquisition system and others auxiliary equipment.

The aim of this paper is to point out the reasoning that leads to evaluate a reduction in uncertainty of the INRiM's measurement systems up to 200 kV.

II. LIGHTNING IMPULSE MEASURING SYSTEM

The INRiM's LATFC laboratory owns a Lightning Impulse Reference Measuring System that consist in two different voltage dividers, the first is the reference for LI up to 200 kV (subject of this paper) the second one increases the voltage level up to 600 kV, National Instruments' scope card PXIe-5124 and self-made software. The LI source is a generator capable of generate a lightning impulse up to 800 kV, for in-house operations, while on-site measurements are carried out with the customer generation system. Below the components of the system for this work are described.

A. Voltage divider

Fig. 1 shows the SAGI 304, a resistive divider developed by means of lab specification. Due to its dimensions and characteristics, it could be possible to use only up to 200 kV.

B. Digitizer

The digitizer that is used for the data acquisition is the National Instruments' scope PXIe-5124, whose characteristics are:

- Max sampling rate: 200 MS/s
- Resolution: 12 bits

C. Software

The software used for the measurement of lightning impulse in LATFC's laboratory is developed in-house with LabVIEW. It could dialogue with the different acquisition systems used in the laboratory for tests and calibrations.

The algorithm developed according to the IEC 60060-1 [3] and the IEC 61083 series [4, 5]. The algorithm has been validated for all the lightning impulse waveforms with respect to the values reported in the IEC 61083-2 [5].



Fig. 1. SAGI 304 resistive divider up to 200 kV.

D. LI Generator

The LATFC's generator, an HAEFELY SGSA 800/40 shown in Fig. 2, is a multi-stage impulse system, with eight stages where each stage can hold up to 100 kV with a total of 800 kV. It could be partialized if necessary, for the generation below 100 kV.



Fig. 2. LATFC's Haefely Impulse generator.

III. IMPROVEMENT OF UNCERTAINTY TARGET

Starting from comparison performed in the years 2016-2020, the entire measurement system was studied deeper to pursue the objective to reduce the CMCs declared. The uncertainties declared for complete lightning impulse (LI) during the comparison, current CMCs, are reported in Table 1:

Table 1. Expanded uncertainty declared.

Parameter	Expanded uncertainty
Peak Voltage, U_t	0,5%
Front time, T_1	3%
Time to half-value, T_2	3%
Overshoot, β'	1%

Where, as described in IEC 60060 - 1 [3]:

- U_t is the maximum value of the test voltage curve;
- T_1 is a virtual parameter defined as $1/0.6$ times the interval T between the instants when the impulse is 30 % and 90 % of the peak value (points A and B, Fig. 3);
- T_2 is the time interval between the virtual origin O_1 and the instant when the test voltage has decreased to half the test voltage value;
- β' is the relative overshoot magnitude

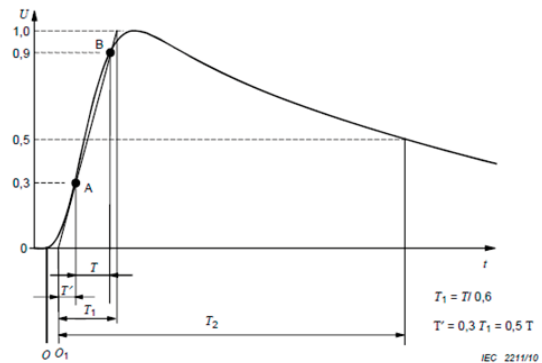

Fig. 3. Lightning impulse time parameters, from IEC 60060-1

The INRiM's comparison results has been reported without any improvement in the uncertainty of time parameters due to the unavailability of the old calibration system due to a failure and the consequent impossibility of a direct verification, before the comparison, to evaluate the extent of the measurement uncertainty.

The objective is to reduce the expanded uncertainty until obtaining the value targets reported in Table 2, requested for commercial operation in the calibration of high voltage lighting impulse measuring systems:

Table 2. Expanded uncertainty targets.

Parameter	Expanded uncertainty
Peak Voltage, U_t	0,5%
Front time, T_1	1,5%
Time to half-value, T_2	1%
Overshoot, β'	0,5%

The parameter reported in Table 2 was hypothesized starting from step response of the entire measurement system obtained during comparison, for an ideal LI waveform.

IV. REANALYSIS OF INTERNATIONAL COMPARISON RESULTS

To support the reduction of the CMCs uncertainty it was performed a complete reanalysis of the comparison results with the expanded uncertainty target.

The reanalysis includes the recalculation of comparison reference value (CRV) as described in the final report [1], which is considered as an estimation of the measurand according to the measurements provided by the participating laboratories [1, 2], reported in equation (1):

$$CRV = \frac{\sum_{i=1}^N x_i u^{-2}(x_i)}{\sum_{i=1}^N u^{-2}(x_i)} \quad (1)$$

Where:

- x_i are the errors provided by the participants for the TRMS readings
- $u(x_i)$ are the corresponding standard uncertainties.

To not be verbose, in this paper were reported only the results for one significant type of LI, where the higher value in the degree of equivalence has been found for the most critical parameter T_1 . Specifically, given that the uncertainty on the test voltage value, peak measurement, does not change, only the measurements relating to times were reported.

All the tables and figures are referred to Short-P100 case, the worst one in this analysis. Short-P100 is the LI with a positive peak voltage of 100 kV and front time of 0,84 μ s that is the fastest front time that could be performed according to the IEC 60060-1 [3].

Fig. 4 and Table 3 shown the values relatives to the T_1 measurements performed during the comparison, where:

- Δx_i is the difference percentage between the measurement of the laboratory and the CRV;
- $U(\Delta x_i)$ is the expanded uncertainty related to Δx_i ;

- E_n is the degree of equivalence of laboratory, if it is under the value 1 it is considered acceptable; calculated as shown in equation (2):

$$E_n = \frac{x_i - CRV}{2 \cdot \sqrt{u^2(x_i) - u^2(CRV)}} \quad (2)$$

- CRV is the comparison reference value;
- $U(CRV)$ is the expanded uncertainty of CRV, calculated as shown in equation (3):

$$U(CRV) = 2 \cdot \frac{1}{\sqrt{\sum_{i=1}^N u^2(x_i)}} \quad (3)$$

- Pr denotes “probability of” is a parameter used for consistency check. If Pr is under 5% the check is considered failed. calculated as shown in equation (4, 5):

$$Pr\{\chi^2(v) > \chi_{obs}^2\} < 5\% \quad (4)$$

Where:

$\nu = N - 1$ is the number of degrees of freedom

$$\chi_{obs}^2 = \sum_{i=1}^N \frac{(x_i - CRV)^2}{u^2(x_i)} \quad (5)$$

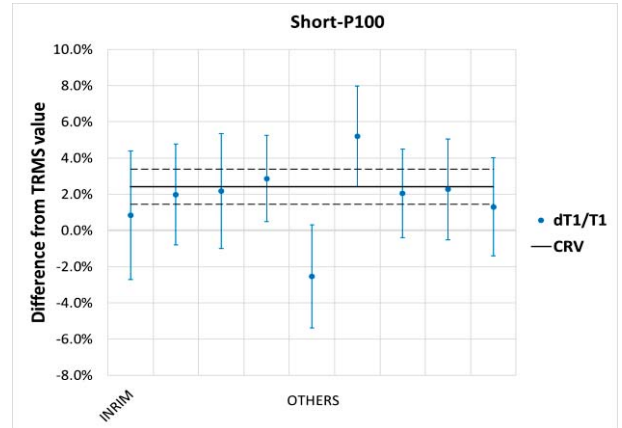

Fig. 4. T_1 's data results of comparison.

Table 3. T_1 's data results of comparison.

LAB	Δx_i	$U(\Delta x_i)$	E_n
INRIM	-1,57%	3,43%	-0,46
	-0,43%	2,61%	-0,17
OTHERS	-0,25%	3,03%	-0,08
	0,45%	2,17%	0,21
	-4,95%	3,02%	-1,64
	2,78%	2,61%	1,06

-0,37%	2,24%	-0,17
-0,15%	2,61%	-0,06
-1,11%	2,53%	-0,44
CRV	U(CRV)	Pr
2,41%	0,98%	57%

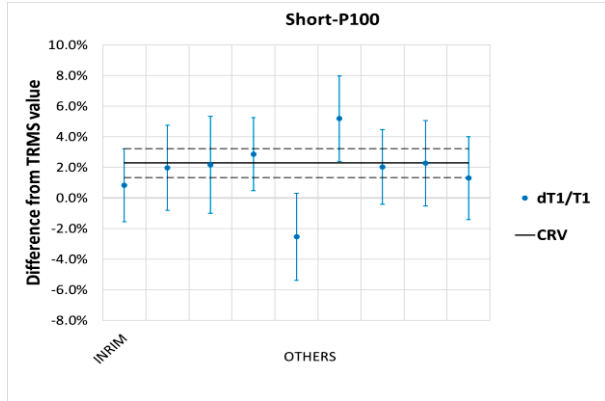

Fig. 5. T_1 's data after recalculation.

Table 4. T_1 's data after recalculation.

LAB	Δx_i	$U(\Delta x_i)$	E_n
OTHERS	-1,44%	2,21%	-0,65
	-0,30%	2,62%	-0,12
	-0,11%	3,04%	-0,04
	0,58%	2,19%	0,27
	-4,82%	3,00%	-1,61
	2,91%	2,63%	1,11
	-0,24%	2,26%	-0,11
	-0,01%	2,62%	-0,01
	-0,98%	2,54%	-0,38
CRV	U(CRV)	Pr	
2,28%	0,94%	47%	

Fig. 5 and Table 4 reported the results of the comparison if INRIM reduced the declared expanded uncertainty from 3% to 1,5% for the front time T_1 parameter. It is possible to see that no one of the other partners present a variation in the degree of equivalence that change their status or their compliance with the comparison results. For the INRIM measurements the degree of equivalence is still under the unit value.

The variation in the CRV uncertainty values shows an improvement in the comparison results, due to its reduction, the reduction of the probability Pr is negligible

for the analysis, considering that the minimum acceptable value is 5 %.

Comparing the figures, it is possible to notice that the INRIM's uncertainty still intersect the CRV.

Fig. 6 and Table 5 shortly shown the comparison results before and after reanalysis relative of T_2 , time to half value.

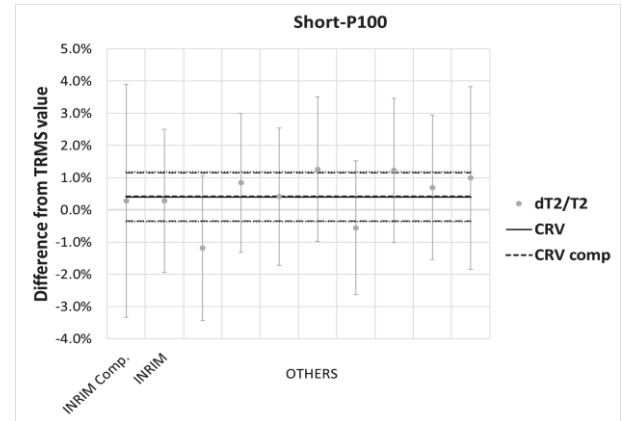

Fig. 6. T_2 's comparison and reanalysis data.

Table 5. T_2 's INRIM data.

INRiM Lab	Δx_i	$U(\Delta x_i)$	E_n
Comparison	-0,13%	3,53%	-0,04
Reanalysis	-0,12%	2,10%	-0,06
CRV	U(CRV)	Pr	
Comparison	0,35%	0,78%	80%
Reanalysis	0,40%	0,75%	82%

Also, in the case of T_2 it is possible to observe, in Fig. 6, that with the reduction of INRIM's uncertainty the CRV change is negligible and that changes don't affect the compliance for the other participants of the comparison.

V. CONVOLUTION METHOD TO VALIDATE REANALYSIS

To validate the results of the comparison reanalysis, a determination of the dynamic behavior from step response measurements was performed as described in IEC 60060 – 2 [6].

A step generator based on the voltage collapse, by means a relay with mercury-wetted contacts commutation, has been used to perform experimental measurement of dynamic response of the divider. The acquisition system National Instruments' scope card PXIe-5124 used for this evaluation is the same of the LI measurements.

The convolution method consists, as described in Annex D of IEC 60060-2, in a calculation of the output of

the measuring system starting from step response and an impulse, representative of the waveform normally measured during calibration operations.

For this work have been used the most significant reference waveshape, related to calibration, generated from the test data generator (TDG), described in IEC 61083-2 [5], used for the software algorithm validation.

The step response measurements are used to characterize a measuring system, it consists in a measurement of the output of the system's behaviour while a step occur. Voltage step generators are designed and used for this specific tests.

The step response is also used to calculate parameters that are recommended for LI reference measuring systems. Table 6 shown the recommended parameter values that are described in IEC 60060-2 [6] and INRiM's reference measuring system step response values.

Table 6. Step response parameters for LI reference measuring systems.

	Recommended	INRiM's SAGI304
Experimental response TN	≤ 15 ns	10 ns
Settling time t_s	≤ 200 ns	85 ns
Partial response T_α	≤ 30 ns	10 ns

For this validation was used a step response performed during comparison, in the same laboratory layout, and the TDG file was rescaled to be compatible, as test voltage value only, with the voltage that the reference measuring system can measure, up to 200 kV.

In Fig. 7 it is possible to observe the original TDG waveform for LI-A1 [5], solid blue line, and the waveform resulting from the convolution, dashed orange line. The convoluted waveform was translated, in time and value, only to guarantee a better visibility.

In Table 7 were reported the results of the convolution methods, compared, as relative variation, with the value reported in IEC 61083-2 standard, performed for different reference waveforms.

For each waveform it could be appreciated that the results are less than new expanded uncertainty target for all the parameters.

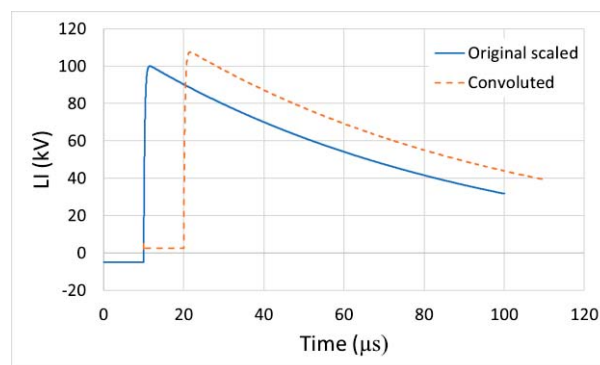

Fig. 7. Comparison between LI A1 reference and convoluted waveforms.

Table 7. Results of convolution method.

TDG	U_t	T_1	T_2	β'
LI A1	0,05%	1,19%	0,25%	0,13
LI A3	0,12%	0,18%	0,44%	0,29
LI A4	0,15%	0,68%	0,48%	0,28
LI A11	0,18%	1,18%	0,46%	0,37
LI M6	0,04%	1,11%	0,07%	0,06
LI M10	0,01%	0,96%	0,03%	0,09

VI. CONCLUSIONS

The new uncertainty targets for lightning impulse parameters have been integrated in the EURAMET.EM-S42 calculation to assure the reliability of the values. The new calculation of the comparison reference value (CRV) has not changed the results for other partners involved in the measurements. The degree of equivalence is, for all the intercomparison levels, $E_n < 1$, assuring a good reliability of the measurements results.

The new uncertainty values have been verified applying a convolution calculation between the measured step response of the high voltage divider and most significant waveforms obtained by the reference standard IEC 61083-2:2014. The calculation of the convolution results by means of INRiM algorithm have been compared with the standard reported value for all the parameters.

In consideration of this reanalysis the LATFC-INRiM laboratory can reconsider the expanded uncertainty for CMCs up to 200 kV, with an important improvement especially for the time parameters T_1 and T_2 .

Further analysis could be performed also for the higher voltage levels with the measuring system up to 600 kV.

REFERENCES

- [1] <https://www.bipm.org/documents/20126/48859014/EURAMET.EM-S42.pdf/9faf30cc-78be-379f-771a->

4e6133ce6a0f.

- [2] J. Hällström, A.-P. Elg, J. Havunen and F. Garnacho, Supplementary comparison EURAMET.EM-S42, comparison of lightning impulse (LI) reference measuring systems, Metrologia, 2020.
- [3] IEC 60060-1 High-voltage test techniques - Part 1: General definitions and test requirements, 2010-09.
- [4] IEC 61083-1 Instruments and software used for measurements in high-voltage impulse tests - Part 1: Requirements for instruments.
- [5] IEC 61083-2 Instruments and software used for measurement in high-voltage and high current tests - Part 2: Requirements for software for tests with impulse voltages and currents.
- [6] IEC 60060-2 High-voltage test techniques - Part 2: Measuring systems, 2010-11