

A low-power automated measurement system for pulsed eddy current based inspection of oil-well casing

Davorin Ambruš¹, Vedran Bilas², Darko Vasić²

¹ *Brodarski Institute, Ave. V. Holjevca 20, HR-10020 Zagreb, Croatia, Phone: +385 1 6504 328,*

Fax: +385 1 6504 400, davorin.ambrus@hrbi.hr

² *Faculty of Electrical Engineering and Computing, University of Zagreb, Unska 3, HR-10000 Zagreb, Croatia, Phone: +385 1 6129 974, Fax: +385 1 6129 652, vedran.bilas@fer.hr, darko.vasic@fer.hr*

Abstract - This paper presents a design of a multichannel measurement system for nondestructive inspection of oil-well casing's mechanical properties (i.e. tube wall thickness and inner diameter), employing pulsed eddy current (PEC) technique. A specific feature of the system is its operation in high-temperature environment (typically up to 175°C), which requires simple and robust circuits, low part-count probe design, low power consumption and proper automated measurement algorithms to ensure reliable operation. Based on our previous work on PEC method, we propose an inspection tool, consisted of a simple, low-length three-coil probe, switch-mode power conditioning and transmitter excitation unit, and a low-power data acquisition and telemetry circuit. Preliminary results of our high-temperature functional tests confirm reliable operation of the inspection tool and provide additional verification of the previously proposed PEC methodology for measurements in harsh environments.

I. Introduction

The methods of nondestructive testing (NDT) are highly important in down-hole inspection of oil-well casings because of harsh environmental conditions, and ecological and economical risks associated with oil-well breakdown. Electromagnetic NDT methods based on the application of eddy currents (EC) are extensively used for inspection of thick ferromagnetic tubes, such as oil-well casings [1].

Traditional EC instruments used for measurement of the tube wall thickness and inner diameter typically employ several exciter-detector coil pairs (remote field eddy current - RFEC coils and 'caliper' coils) with multi-frequency high-power harmonic excitation [2]. Practical implementation of such complex and physically large inspection tools in a harsh environment of an oil-well often becomes quite cumbersome.

In our previous work we have established and experimentally verified a methodology for simultaneous measurement of the ferromagnetic tube wall thickness and inner diameter with a simple, relatively short, two-coil EC probe with pulse excitation [3]. We have shown that the application of pulsed eddy current (PEC) enables separation in time of responses sensitive to inner diameter and wall thickness of the ferromagnetic tube for the same detector location [4]. Detector responses related to these quantities can be made commensurable by choosing adequate probe length (typically 1-2 tube diameters between exciter and detector coil), which significantly simplifies electronic design of the measuring channel.

In this paper, we present a practical realization of an automated measurement system that utilizes major potential advantages of PEC technique for high-temperature operation (low power consumption, low-length probe, simple and robust design). The inspection tool has been designed by combining the use of high-temperature rated components for performance-critical circuitry (A/D converter, precision voltage references, digital clock generator, etc.), with low-cost commercial-grade parts, thoroughly tested for functionality and reliability above their manufacturer-specified temperature range. The latter procedure is often called thermal "uprating" and presents a powerful engineering tool in designing electronics for relatively short-term high-temperature applications [5].

II. Automated measurement system design

A. System configuration and measurement methodology

A basic structure of the proposed measurement system is given in Figure 1. The downhole part of the system (inspection tool) consists of the three main building blocks: probe section with a single exciter coil and two detector coils for absolute / differential measurement, power conditioning and excitation generation block, and a mixed-signal block for data acquisition and telemetry protocol functions.

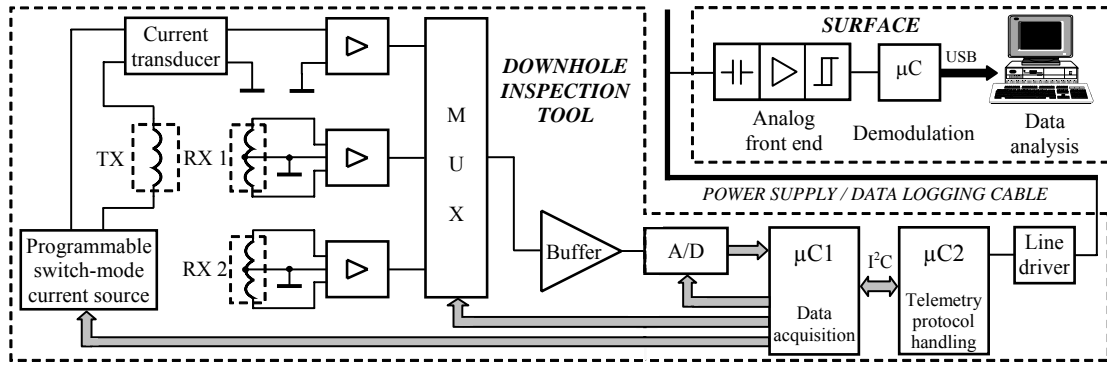

Figure 1. Principle block-diagram of the PEC-based automated measurement system.

Communication with the surface is realised via DC power supply cable, by applying digital powerline modulation. The topside electronics performs primary analog processing and demodulation of the received signal. Measured average wall thickness, inner diameter, and other data acquired from the downhole tool (excitation current, temperature, etc.) are transferred to PC via USB interface, for further processing, visualization and off-line analysis.

Basic configuration and mechanical design of the inspection tool itself are given in Figure 2. The proper axial movement of the tool along the inside of the casing is provided by a pair of centralizers, located from each side of the tool. In order to increase sensitivity and to obtain low-power operation of the eddy current probe, lift-off must be minimized. However, it is also important to note that small lift-off variations caused by centralizing tolerances do not significantly influence the relative accuracy of the internal diameter (ID) measurement. This is due to the fact that the probe only senses the average ID value, according to the coil configuration shown in Figure 2.

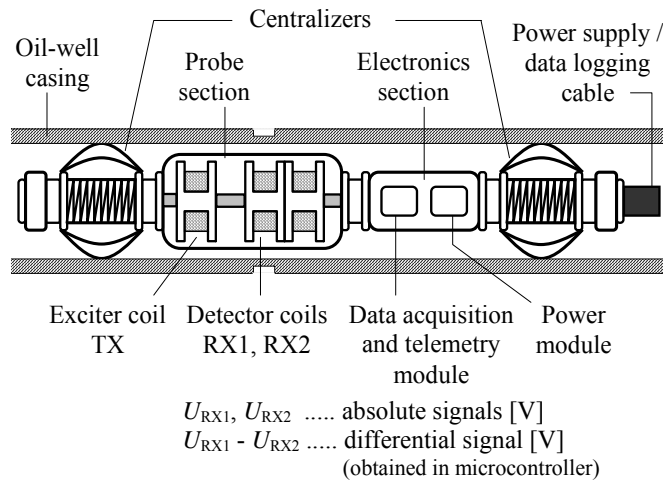

Figure 2. Mechanical design of the oil-well casing inspection tool.

Typical response of a detector coil voltage on pulse excitation, for a given probe configuration, is shown in Figure 3. Specific features of the detected signal are zero-crossing time, t_{ZC} and voltage magnitude, U_{CL} , which are used in measuring the tube wall thickness and the internal diameter, respectively [3].

The application of pulse excitation provides significant reduction of the tool power consumption, which is crucial for reliable operation in harsh environment of an oil-well. Total power consumption of the tool is dominantly affected by the excitation current magnitude and duty cycle, which should be adjusted according to the mechanical and electromagnetic properties of a casing under test. For example, a thicker casing wall requires longer period between two excitation pulses (larger eddy current diffusion time constant), but in general, also a higher excitation magnitude.

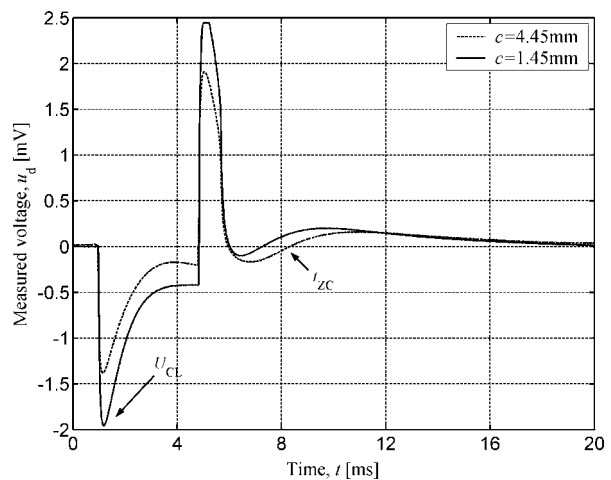

Figure 3. Typical waveform of a PEC probe detector coil voltage for two different wall thicknesses (absolute measurement)

It can be seen from Figure 1 that the casing inspection tool operates within a telemetry system, in which duration of each sequence of excitation generation and detector response measurement has to be adjusted to the transmission protocol timing parameters. Furthermore, several measurements are typically needed per one data block transmission, in order to perform simple averaging of measured casing parameters. This is important for reducing “road noise”, inherent to practically all of the oil-well inspection instruments.

From the latter discussion, it is evident that the measurement system parameters, such as power consumption, measurement quality for particular types of casings, transmission protocol and speed, etc. are mutually dependant and that various trade-offs need to be taken into account to obtain optimal performance. In the particular case of our prototype tool, developed for inspection of a standard 2 3/8 “ casing (Figure 4.), total power consumption of less then 5W is achieved, which was one of the priorities of the new measurement system design. Relative accuracy of thickness measurement of up to $\pm 1\text{mm}$ and resolution of up to $\pm 0.25\text{mm}$ are expected to be feasible with the newly designed tool.

B. Measuring probe

A three-coil probe configuration from Figure 2 enables two absolute and one differential signal to be obtained. Differential measurement exhibits higher sensitivity to abrupt changes of the wall thickness and is therefore useful for detection of localized defects with clear 'boundaries' [6]. Both absolute and differential signals depend on electromagnetic properties (permeability and conductivity) of the particular casing, so that gauging on the intact part of the tube must be performed prior to inspection.

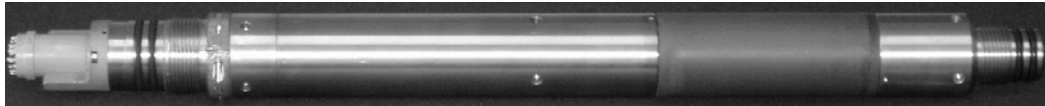

Figure 4. Photograph of the measuring probe section (coil arrangement from Figure 2), designed for inspection of oil-well casing with standard outside diameter of 2 3/8”.

C. Power conditioning and transmitter excitation

Power conditioning section of the PEC tool provides multiple regulated supply voltages for analog and digital circuitry and is realized as an efficient step-down forward-type switching DC/DC converter. Forward type topology was preferred over flyback, because of lower generated noise and lower values of output filter capacitors, which usually present critical points in high-temperature design of power electronics [7].

Pulse current source, used for driving the exciter coil, is also based on switch-mode design, which provides low power dissipation, but also enables digital control of the excitation current magnitude. In this way, the overall robustness of the tool can be increased by implementing algorithms for automatic excitation current adjustment, based on optimal features of the detector coil signal.

D. Data acquisition and telemetry module

The data acquisition section consists of the three separate analog channels and a simple, commercial-grade 8-bit microcontroller which handles all the functions of pulse generation, data sampling and A/D conversion. At the end of each measurement cycle, obtained values of t_{ZC} and U_{CL} (both absolute and differential) are transferred via I²C interface to the second microcontroller, which transmits data to the surface, according to the specified telemetry protocol. Proper high-temperature design techniques, such as lowering the CPU clock frequency, are required to obtain reliable operation of the circuitry [8].

Figure 5 shows a photo-caption of the data acquisition and telemetry module board. High-temperature rated components in hermetically sealed metal packages are clearly noticeable (A/D converter, precision voltage reference, clock frequency generator). Other, commercial-grade components, such as microcontrollers, amplifiers, etc. are packed in standard ceramic packages.



Figure 5. Photograph of the data acquisition and telemetry module printed circuit board.

III. Experimental set-up and functional tests

High-temperature functionality and performance of a designed inspection tool (main electronic modules) was tested in a controlled-temperature environment (climate chamber Weiss Technik 125SB). The environment temperature was ramped from 25°C to 125°C in 20°C intervals and from 125°C to 175°C in 10°C intervals. The electronic modules have been kept at each temperature for 20 minutes. Additional 4-hour 175°C burn-in test was performed at the end of a testing procedure.

Preliminary results confirm reliable operation of a developed oil-well casing inspection tool, and show that PEC technique (already verified in our previous work by using standard laboratory instruments) can be successfully applied for real-time measurements in harsh environment of an oil-well.

IV. Conclusions

A pulsed eddy current based system for automated measurement of the average wall thickness and inner diameter of oil-well casings has been designed. The presented inspection tool has low power consumption, low-length three-coil probe and simple transducer electronics. This is, in general, a significant improvement of present eddy current tools for nondestructive inspection of thick ferromagnetic tubes, with respect to design complexity and high-temperature operation reliability.

Acknowledgement

This research has been partly supported by the Croatian Ministry of Science, Education and Sports through grant number ZP-0036-007, and by Hotwell, Austria.

References

- [1] J. Blitz, *Electrical and magnetic methods of non-destructive testing*, Chapman & Hall, London, 1997.
- [2] J. Yin, J. P. de Gyves, M. Lu, "In-Place Detection of Internal and External Corrosion for Underground Casing Pipes", in *Proc. IEEE Int. Conf. on Industrial Technology*, Guangzhou, China, pp. 789-793, December 1994.
- [3] D. Vasić, V. Bilas, D. Ambruš, "Pulsed remote field technique in ferromagnetic tube wall thickness and inner diameter measurement", *XVII IMEKO World Congress*, Dubrovnik, Croatia, pp. 912-916, June 2003.
- [4] D. Vasić, V. Bilas, D. Ambruš, "Pulsed eddy current nondestructive testing of ferromagnetic tubes", in *Proc. 20th IEEE Instrum. Meas. Technol. Conf.*, Vail, CO, USA, 2003, pp. 1120-1125.
- [5] P. McCluskey, K. Menash, C. O'Connor, A. Gallo, "Reliable use of commercial technology in high temperature environments", *Microelectronics Reliability*, vol. 40, pp. 1671-1678, 2000.
- [6] E. Cardelli, N. Esposito, M. Raugi, "Electromagnetic Analysis of RFEC Differential Probes", *IEEE Transactions on Magnetics*, vol. 23, no. 2, pp. 1849-1852, March 1993.
- [7] A. I. Pressman, *Switching power supply design*, McGraw-Hill, Inc., New York, USA, 1998.
- [8] J. Goetz, "Sensors That Can Take the Heat, Part 3: Design Techniques for High Temperature Applications", *Sensors*, pp. 22-35, August 2000.