

FUZZY EXPERT SYSTEM FOR POWER QUALITY ASSESSMENT

Marius Pislaru ¹, Alexandru Trandabat ², Stefan Ursache²

¹ "Gh. Asachi" Technical University, Iasi Management and Engineering of Production Systems
Department Bd. D. Mangeron, 53, 700050, Iasi, Romania, phone +40 232 278683, Fax +40 232
230491, e-mail: mpislaru@misp.tuiasi.ro

² "Gh. Asachi" Technical University, Iasi, Faculty of Electrical Engineering, Bd. D. Mangeron, 53,
700050, Iasi, Romania, phone +40232278680, Fax +40232237627

Abstract- This paper describes a fuzzy expert system in order to understand and deal with power quality problems encountered in distribution systems in a better way. Because of the technology and software now available this monitoring is highly effective, the fuzzy expert system not only can provide information about the quality of the power and the causes of power system disturbances, but it can identify problem conditions throughout the system before they cause widespread customer complains and equipment malfunctions. The loads in customer premises have also been the source of power quality problems. It has become important for the utilities to understand the causes for power quality problems and find ways to avoid them. The fuzzy expert system can be used in a utility for personnel training and customer education.

I. Introduction

Power quality is an issue that is becoming increasingly important to electricity consumers at all levels of usage. Sensitive equipment and non-linear loads are now more commonplace in both the industrial commercial sectors and the domestic environment. Because of this a heightened awareness of power quality is developing amongst electricity users. "Power Quality" (PQ) is a term often used today for describing an important aspect of the electricity supply and utilization. First of all, the characteristics of load have become so complex that the voltage and current of the power line connected with these loads are easy to be distorted. Lately, for example, non-linear loads with power electronic interface that generate large harmonic current have been greatly increased in power system. Then, the end-user equipments have become more sensitive to power quality than before. Telecommunication devices, adjustable-speed drives, process-control equipments and computers are notorious for their sensitivity to power quality. And like a paradox the same sophisticated appliances also cause harmonic distortion, reduced efficiency, and other power quality problems.

The impact of the power quality problems on system operation and customer satisfaction have been recognized by the utilities, which have adopted several strategies to deal with the causes and consequences of deficient power quality. The classical expert systems are restricted to the two values of true and false in reasoning which is few in the real world. This is why there is a need to combine expert systems with fuzzy logic. Fuzzy reasoning is the inference of a possible imprecise conclusion from a set of possible imprecise premises. Fuzzy expert systems combine the usefulness of fuzzy logic and the rule base of the expert system.

In this paper we are discussing about a proposed fuzzy expert system in order to deal with the most significant power disturbances.

A. An issue about power quality problems

A power quality problem could be defined as "an occurrence manifested in voltage, current or frequency deviations, which results in failure or misoperation of end-use equipment". Commercial customers have become more demanding in their request concerning "quality" of power they purchase. Variation in flow or voltage can actually damage and disrupt sensitive electronics, computers and other. As modern society relies more heavily on high tech-processes, power quality has become even more critical.

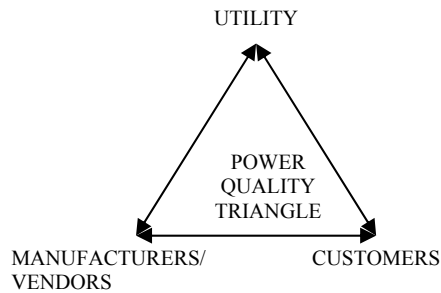

Fig. 1. Power quality Triangle

“Power Quality Triangle” combined with utility operations, customer load types and equipment designs influence the power quality. Distribution utilities and their customers, along with their engineering equipment manufacturers and vendors generate, propagate and receive power quality problems.

Power quality can be evaluated by its effect on the performance of equipment. Weather conditions and other factors may preclude utilities from providing power at constant voltage and constant frequency. The main types of voltage disturbances that occur in electrical power distribution systems include the following: voltage sags, voltage swells, transients, interruption distortion flicker, noise frequency deviations. These voltage disturbances will cause various power quality problems like electrical equipment damage, malfunction of computers and other sensitive equipment. Since power quality issues are multifaceted, the expertise required in the resolution must come from a wide range of disciplines.

II. Overview of the Fuzzy expert system

Fuzzy logic is a scientific tool that permits modeling a system without detailed mathematical descriptions using qualitative as well as quantitative data. Computations are done with words, and the knowledge is represented by IF-THEN linguistic rules. An expert system can be defined as a computer system which emulates the decision-making ability of human expert [2]. The user supplies facts or other information to the expert system and receives expert advice for his queries. The internal organization of an expert system consists of a knowledge-base and an inference engine. The knowledge-base contains the knowledge with which the inference engine draws conclusions. The inference engine is a control structure which helps in generating various hypotheses leading to conclusions that from the basis of answers to user queries.

A power quality problem arising in a utility can be identified with the knowledge of the location of the problem, the equipment involved and information about the monitored quantities like voltage, current, etc at the service entrance. Based on these facts we proposed a fuzzy model in order to cope with the most significant power disturbances. The model uses a number of relevant knowledge bases to represent the interrelations and principles governing the various indicators and components and their contribution to the final decision of the expert system.

The rules and inputs/outputs of each knowledge base are expressed symbolically in the form of words or phrases of a natural language and mathematically as linguistic variables and fuzzy sets. Examples of IF-THEN rules used in the model are:

IF EQ is *good* AND MET is *bad*, THEN PI is *average*;

IF CURRENT is *very bad* OR VOLTAGE is *very bad* OR DD is *very bad* TRANS is *very bad*
THEN MET is *very bad*

The configuration of the model is shown in Fig.2. This model may be viewed as a treelike network of knowledge bases. The inputs of each knowledge base are basic indicators provided by the user or composite indicators collected from other knowledge bases. By using fuzzy logic and IF-THEN rules, these inputs are combined to yield a composite indicator as output, which is then passed on to subsequent knowledge bases. For example, the third-order knowledge base that computes the indicator CURRENT combines PRESSURE, STATUS, and RESPONSE indicators of metering integrity which are outputs of four-order knowledge base. Then CURRENT is used as input to a second order knowledge base to assess PI (problem identification report).

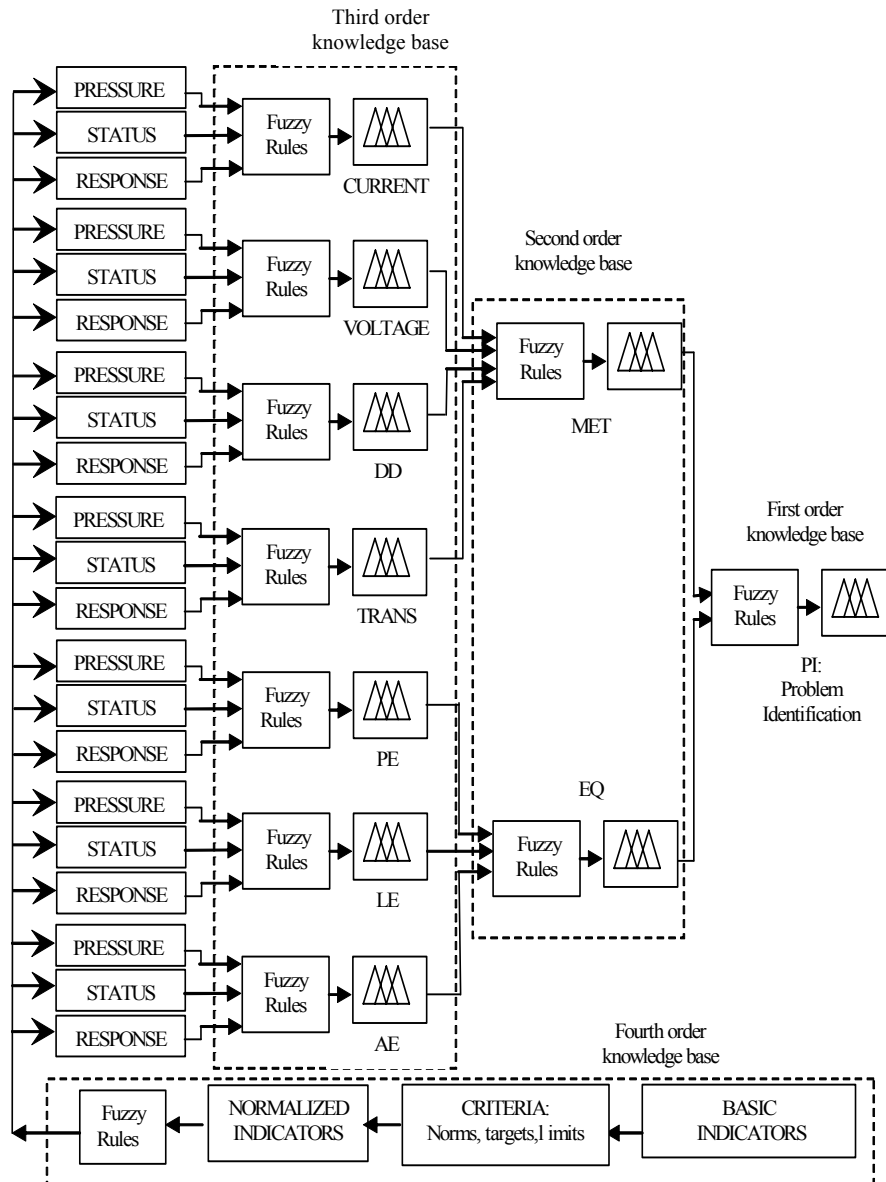

Fig. 2.- Configuration of the fuzzy expert system

The system has two major dimensions EQ (equipment) and MET (metering). These are primary components of problem identification. The equipment dimension comprises three secondary components: PE (power equipment), LE (load equipment) and AE (auxiliary equipment). The variable describing metering are: CURRENT (current), VOLTAGE (voltage), DD (disturbance duration) and TRANS (transients).

To evaluate the secondary components, we adopt the Pressure-State-Response approach. Specifically, the model uses three quantities to describe each secondary component: PRESSURE, STATUS and RESPONSE, called tertiary components. STATUS describes the current overall state of a secondary component we want to assess. It is a function of a number of indicators, which we call basic, because they act as primitives when we compute composite indicators as PRESSURE, STATUS, RESPONSE or CURRENT, VOLTAGE, etc. For example, the STATUS of VOLTAGE represents the effective value of voltage which is displayed by the monitoring devices. PRESSURE is an aggregate measure of the human activities exerts on the state o the corresponding secondary component. Finally, RESPONSE summarizes the actions taken to bring pressure to a level that might result in a better state. The model is flexible in the sense that users can choose the set of indicators and adjust the rules of any knowledge base according to their needs and the characteristics of the system to be assessed.

III. Conclusions

Power Quality problems have many characteristics that can exploit the advantages of an expert system methodology. By its very nature, a solution to power quality problem needs an expert's look at various facets, and a expert system for power quality advisement can serve as a surrogate expert in helping the utility engineer resolve a customer complaint. The expert system identifies the most significant power disturbances and offers solutions to assure the life and reliability of sensitive equipment. Finally, electric power quality is an economic issue. Low power quality causes inefficiency and reduces productivity in business and industry. High power quality helps insure reliable operation of electronic and computer-controlled equipment. High quality power is essential for business and industries to be competitive in local and world markets.

Acknowledgements

This paper was developed within the generous framework offered by type TD project "Neuro-fuzzy systems for quality assurance systems" financed by CNCSIS - Romania.

References

- [1] Heydt, G.T., „Power quality engineering Power Engineering Review”, *IEEE* , Volume: 21 , Issue: 9, 5-7 (2001)
- [2] Giarrantano C. Joseph and Riley, *Expert Systems Principles and Programming*. PWS Publishing Company, Second edition (1994).
- [3] Minakawa, T.; Ichikawa, Y.; Kunugi, M., „Development and implementation of a power system fault diagnosis expert system”, *IEEE Transactions on Power Systems*, Volume: 10 , Issue: 2 932 – 940(1995).
- [4] Jewell, W, „Power quality laboratory testing Power Engineering Review”, *IEEE* , Volume: 22 , Issue: 2 , 13-15 (2002)
- [5] M. Pîslaru, A. Trandabăţ, C. Schreiner, „ Power Quality monitoring using fuzzy expert system” The 8th International *Conference of Development and Application Systems* DAS'06 May 25-27, 2006, Suceava, Romania Volume 2, pp.703-705, ISBN GEN:973-716-208-0
- [6] M. Pîslaru, A. Trandabăţ C. Schreiner, „Quality management evaluation based on fuzzy model” The 7th International Conference *Modern Technologies in Manufacturing MteM* 2005 , Cluj-Napoca , October 6-8, pp.317-320, ISBN 973-9087-83-3